

ITEM NO.	PART NUMBER	DESCRIPTION	QTY.
1	01-2046-7	SCR., SHC 5/16-18 X 1.25 BLOX	8
2	01-2059	WASHER, LOCK, STEEL, 5/16 BLOX	8
3	01-2302	PIN, DOWEL, 1/8 X 1/2, ALLOY	1
4	04-01-902	O-RING, BUNA 70, 902	6
5	04-25-228	O-RING, BUNA 90, -228	1
6	04-25-230	O-RING, BUNA 90, -230	1
7	04-25-230	O-RING, BUNA 90, -230	1
8	04-25-232	O-RING, BUNA 90, -232	1
9	04-31-228	BACKUP RING, BUNA, -228	1
10	04-31-230	BACKUP RING, BUNA, -230	1
11	04-31-232	BACKUP RING, BUNA, -232	2
12	65-0062	BASE, CC, 3J	1
13	65-0063	BODY, CC, 3J	1
14	65-0064	PISTON, CC, 3J	1
15	65-0065	PLUG, PRESSURE, CC	6
16	65-0068	LOCK SCREW, CC, 3J	1

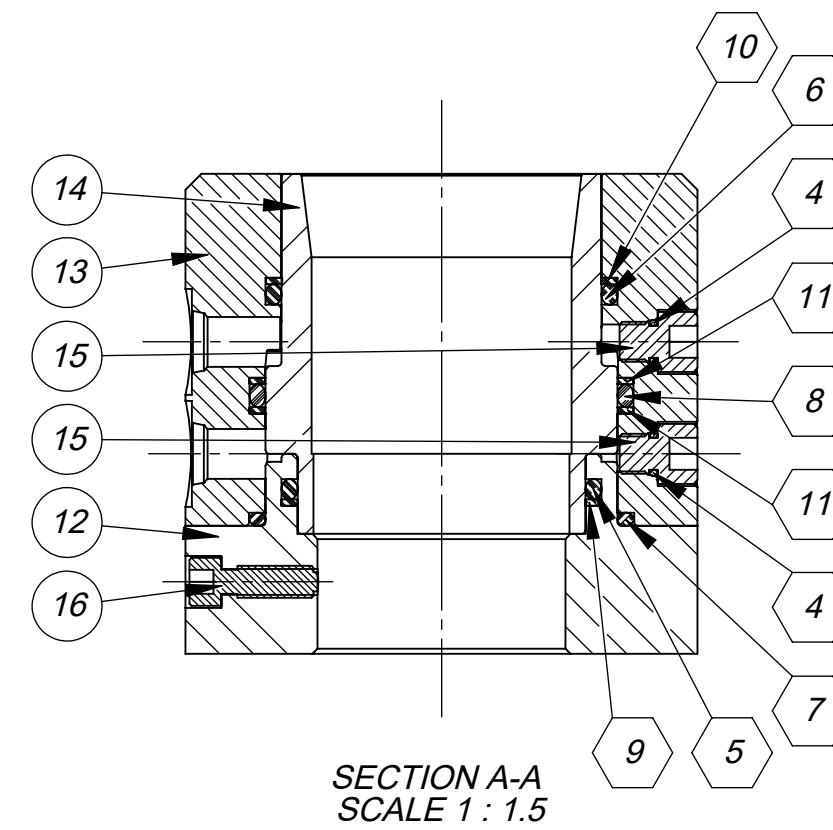

SECTION A-A
SCALE 1 : 1.5

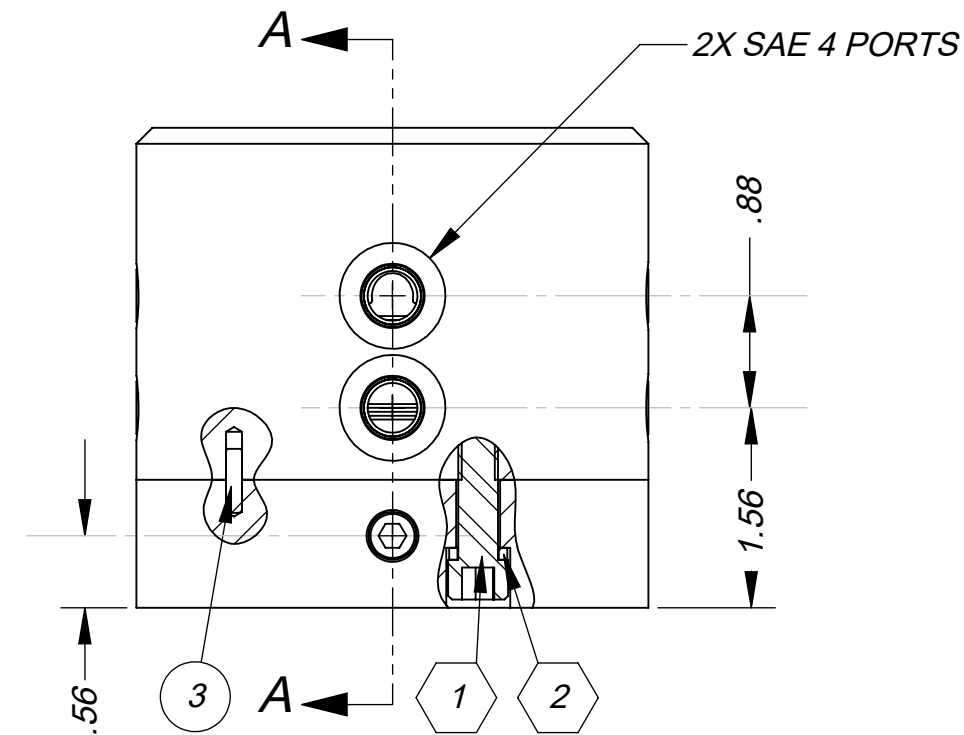
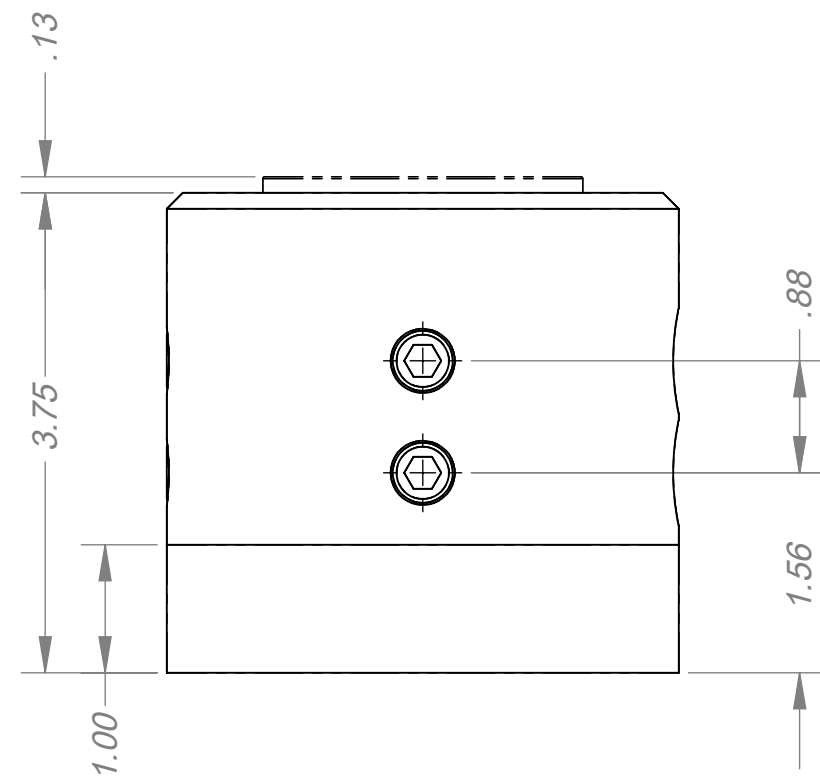
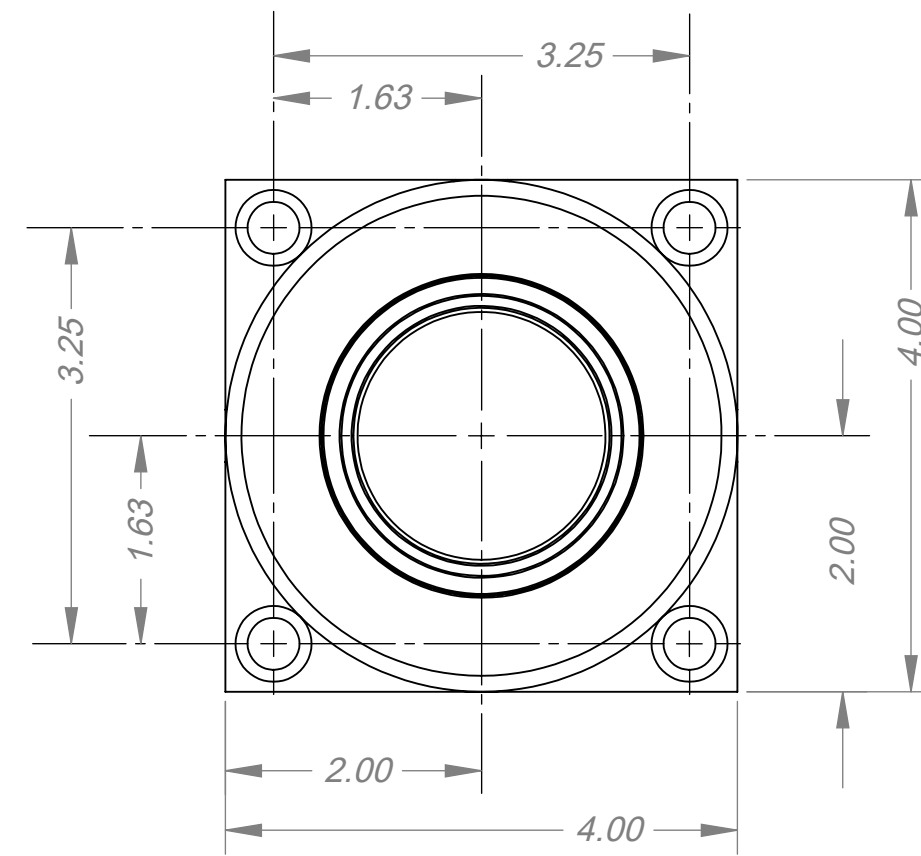
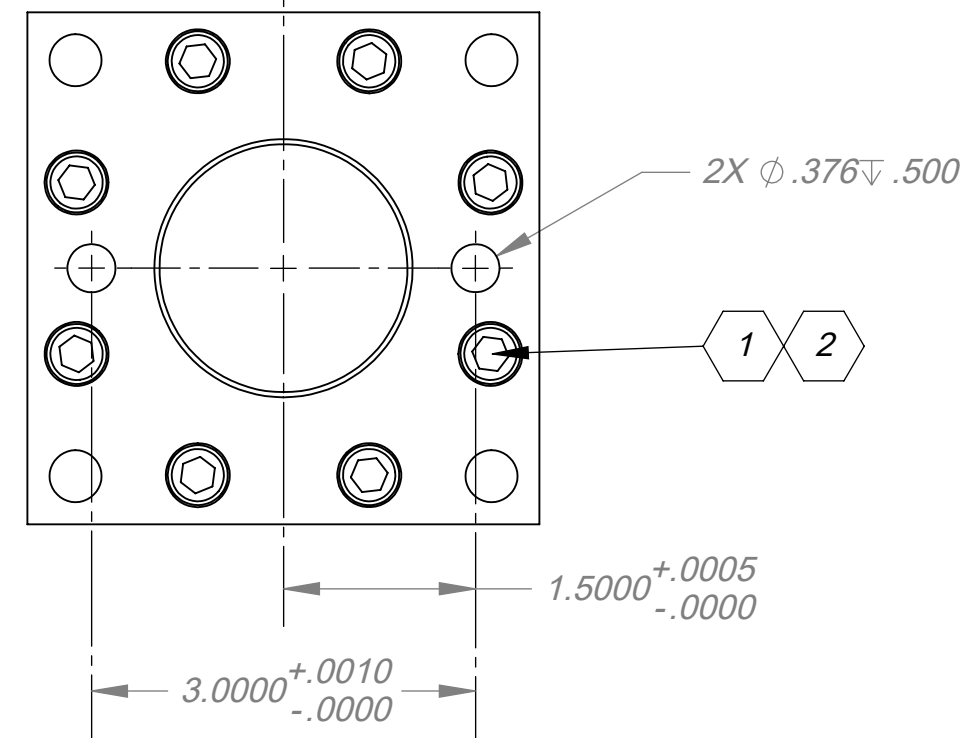
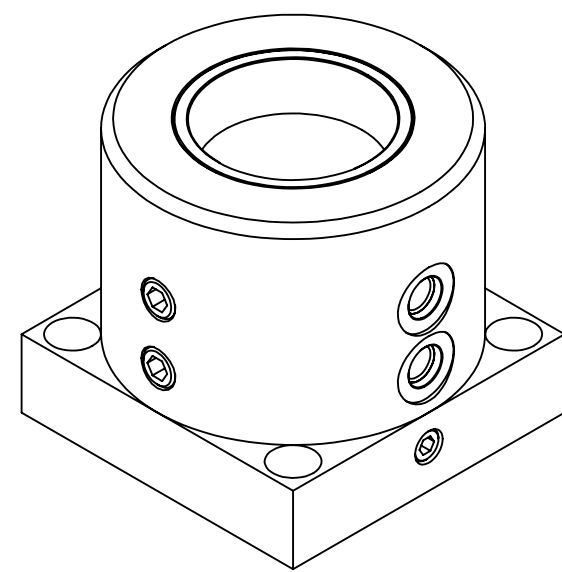

- NOTES:
1. MAX. PRESSURE 3000 PSI.
 2. APPROX. RADIAL CLAMPING FORCE = 6.25 X PRESSURE.
 3. ITEMS IN HEX BALLOONS ARE INCLUDED IN STD. REPAIR KIT 65-0081.

THIS DOCUMENT AND ITS CONTENTS ARE THE PROPERTY OF LEXAIR, INC. THEY ARE FURNISHED TO YOU ON THE FOLLOWING CONDITIONS: NO RIGHT OR LICENSE IN RESPECT OF THIS DOCUMENT OR ITS CONTENTS IS GIVEN OR WANTED IN SUPPLYING THIS DOCUMENT TO YOU. THIS DOCUMENT OR ITS CONTENTS ARE NOT TO BE USED OR TREATED IN ANY MANNER INCONSISTENT WITH THE RIGHTS OF LEXAIR, INC. OR TO ITS DETRIMENT AND ARE NOT TO BE COPIED, REPRODUCED, OR DISCLOSED OF, EXCEPT WITH ITS PRIOR WRITTEN CONSENT.

REVISIONS

A	ECL: 02135 10-11-02 MBR REMOVED STENCIL LOCATION INSTRUCTION.
B	ECL: 06136 12-04-06 MJM REVISED AND REDRAWN.
C	ECL-17030: REMOVED 5000 PSI FROM DESCRIPTION

ECL: 99147 06-23-99 MBR

Tolerances Unless Otherwise Specified:		MATERIAL SPEC.	PC. NO.: 65303
TYPE	FINISHED AS CAST		MADE FROM: SEE B.O.M.
DEC .00	± .015" ± .030"	PROCESS SPEC.	MODEL FILE: 65303.sldasm
DEC .000	± .005" ± .010"		CAD FILE: 65303.slddrw
FRACTIONAL	± 1/64" ± 1/32"		C 65303
ANGLES *	± 1/2" ± 1"		SHEET NO. 1 of 1 SHEETS
FINISH 175 µ in.		SCALE 1:1.5	
COLLET CLOSER, 3J		APPROX. WT. 10.168 LBS	
ASSEMBLY		DRAWN CHECKED APRVD.	
Lexair, Inc.		MJM TPO TPO	
2025 Mercer RD, Lexington, Kentucky 40511		12-04-06 12/04/06 12/04/06	